

## Bevel gear

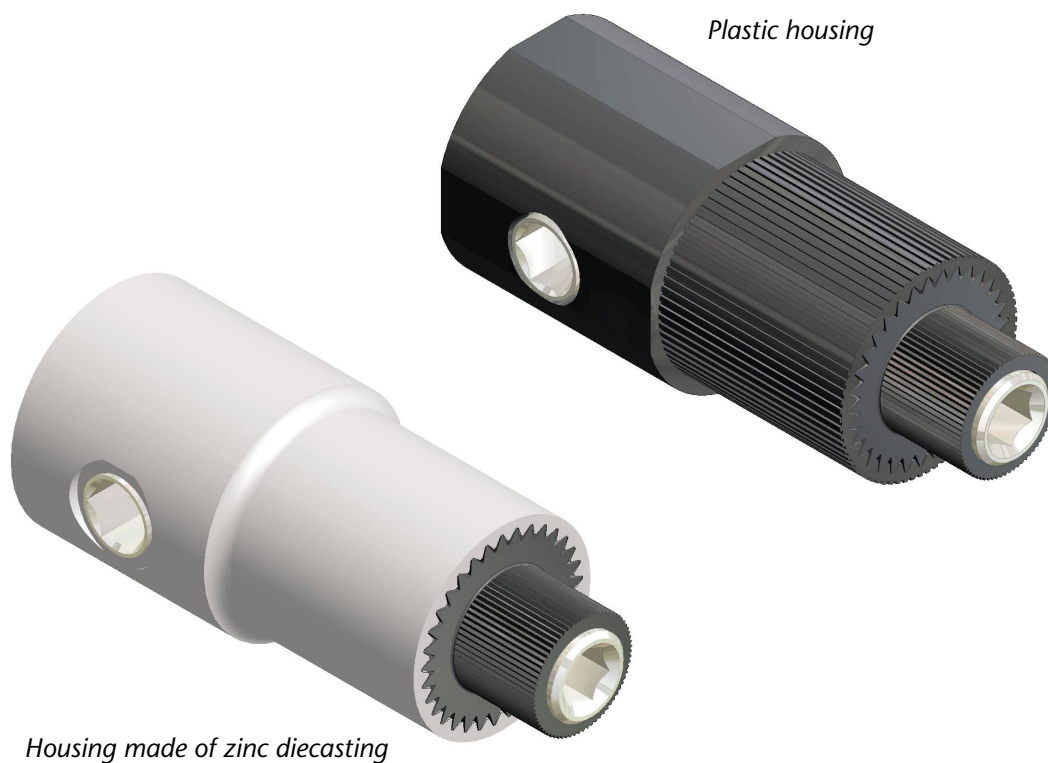

4318  
4324



sun protection

### Description:

Gear for blinds, a left or right mounting is possible. The two gear types are braking on both sides on the output side.

### Special features:

- Ratio 1:1
- Housing made of GFK or die-cast zinc
- Milled steel gear cogs

### Customer specific:

Input and output are modifiable for a customer specific application.

# Bevel gear 4318/4324

Housing made of zinc diecasting

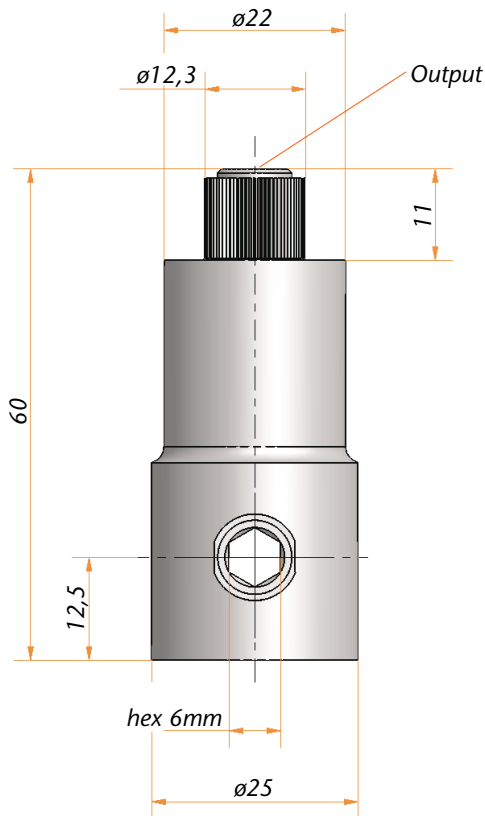

Housing made of plastic

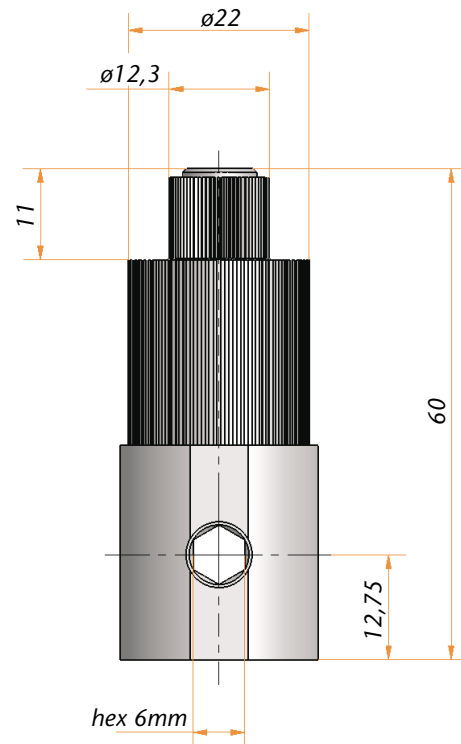

Geiger Gear-holder  
Order-No.: 4326.19-01

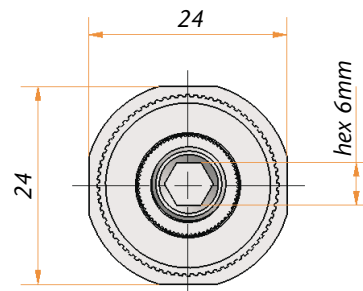
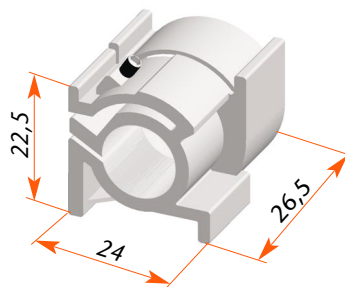
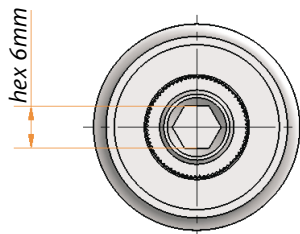

## Technical Data

Baureihe	4318	4324
Ratio	1 : 1	1 : 1
Input in mm	hex 6mm	hex 6mm
Output in mm	hex 6mm	hex 6mm
Number of gear cogs	2	2
Housing material	Plastic	Zinc diecasting
Max. input torque	1,5 Nm	1,5 Nm
Max. output holding torque	3 Nm	3 Nm



## **T.E.A. Machine Components Inc.**

*Your partner in quality engineering components since 2003*

Thank you for downloading product information from TEA's wide range of engineering components.

Now, please contact us for any further information, prices and delivery.

Our contact details are:

**T.E.A. Machine Components Inc.**  
**2281-F Dabney Road**  
**Virginia 23230**  
**U.S.A.**

**Ph: +1-804-342-0004**

**Fax: +1-804-342-0006**

**Web: [www.teausa.net](http://www.teausa.net)**

**Email: [sales@teausa.net](mailto:sales@teausa.net)**

You are assured of prompt and efficient service at all times.