

Metric Bevel Gears



Ratio 1:1 Pressure Angle 20° Material: **Steel 34 Cr 4**

On request: 303 Stainless Steel

Brass - Modules 0.5, 0.75, 1

Zinc die-cast

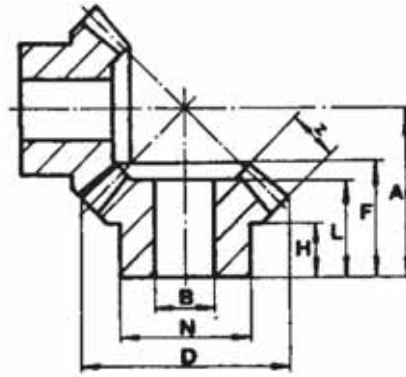

Ratio 1:1

Module	No. of Teeth	Dimensions in mm								Part No.
		B ₁₇	N	D	H	L	F	A	Z	
1.5	16	8	19	26.1	9.5	15.4	16.9	24	5.9	K1100
2.0	16	10	22	34.8	9.5	16.4	18.9	28	8.6	K1101
2.5	16	13	30	43.5	10.0	18.3	21.3	33	10.1	K1102
3.0	16	16	35	52.2	12.5	22.6	26.1	40	12.5	K1103
3.5	16	19	40	60.1	15.0	26.6	30.1	47	13.2	K1104
4.0	16	22	45	69.7	17.5	30.3	35.5	54	16.4	K1105
4.5	16	25	50	78.4	19.5	34.7	40.2	61	18.7	K1106
5.0	16	27	54	87.1	21.0	37.6	43.6	67	19.3	K1107
5.0	19	30	60	102.1	23.5	43.0	49.0	77	24.4	K1108
5.0	22	33	66	117.1	24.0	46.0	52.0	85	27.9	K1109
5.0	26	36	72	137.1	25.0	50.0	56.0	96	32.2	K1110
5.0	30	40	80	157.1	28.0	57.0	63.0	109	37.8	K1111

Maximum capacity kW

Part No.	rpm (n)							
	100	300	500	700	1000	1500	2000	2500
K1100	0.014	0.073	0.110	0.257	0.300	0.368	0.404	0.441
K1101	0.036	0.147	0.220	0.368	0.478	0.700	0.736	0.795
K1102	0.073	0.220	0.368	0.662	0.772	1.030	1.777	1.324
K1103	0.110	0.368	0.662	0.846	1.177	1.472	1.803	2.060
K1104	0.147	0.515	0.846	1.324	1.766	2.281	2.760	
K1105	0.294	0.809	1.435	1.840	2.384	3.312	3.750	
K1106	0.368	1.104	1.766	2.355	3.238	4.416		
K1107	0.441	1.508	2.502	3.385	4.636	5.704		
K1108	0.809	2.134	3.312	4.452	5.851			
K1109	1.777	2.907	4.452	5.888	7.360			
K1110	1.435	3.753	5.888	7.654	9.494			
K1111	1.913	5.004	7.654	9.862	12.430			

$$P = (\text{kW}) \quad TN (\text{Nm}) = \frac{P \cdot 9550}{n}$$

Performance: hardened: 2.5 x value indicated
nitrided: 1.5 x value indicated

SF = 1.4 (safety factor for tooth root stress).

SH = 1.0 (safety factor for hertzian stress) for continuous operation.

All dimensions are subject to change without notice.

Metric Bevel Gears

Ratio 1:1.25 Pressure Angle 20° Material: Steel 34 Cr 4

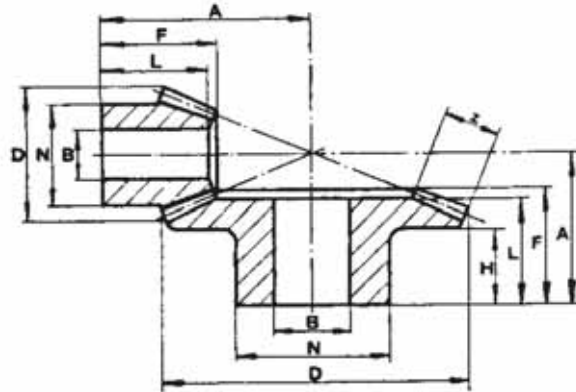

Ratio 1:1.25

Module	No. of Teeth	Dimensions in mm								Part No.
		B _{h7}	N	D	H	L	F	A	Z	
1.5	16	10	20	26.4	9.5	15	16.8	26	6.7	K1120
	20	12	24	31.9	10.4	16	19.0	26	6.7	
2.0	16	12	26	35.1	10.7	18	20.9	33	8.9	K1121
	20	14	28	42.5	13.0	20	23.6	33	8.9	
2.5	16	14	32	43.9	9.9	20	22.8	38	11.2	K1122
	20	16	34	53.1	14.0	23	26.3	38	11.2	
3.0	16	16	36	52.7	9.3	22	25.7	44	13.4	K1123
	20	18	40	63.8	16.0	26	29.9	44	13.4	
3.5	16	20	44	61.5	12.2	27	30.7	52	15.7	K1124
	20	22	48	74.4	19.0	31	35.5	52	15.7	
4.0	16	22	50	70.3	12.5	30	33.6	58	17.9	K1125
	20	24	52	85.0	21.0	34	39.2	58	17.9	
4.5	16	25	54	79.0	17.0	35	39.6	67	20.1	K1126
	20	27	58	95.6	24.0	40	45.9	67	20.1	
5.0	16	28	56	87.8	19.0	39	44.5	75	22.4	K1127
	20	30	60	106.2	28.0	45	51.5	75	22.4	

Maximum capacity kW

Part No.	rpm (n)							
	100	300	500	700	1000	1500	2000	2500
K1120	0.014	0.042	0.069	0.094	0.131	0.185	0.232	0.368
K1121	0.095	0.169	0.184	0.242	0.294	0.404	0.515	0.653
K1122	0.121	0.191	0.331	0.441	0.566	0.846	1.030	1.236
K1123	0.146	0.294	0.552	0.735	0.920	1.288	1.619	1.840
K1124	0.192	0.515	0.883	1.104	1.582	2.024	2.796	
K1125	0.294	0.736	1.288	1.692	2.208	2.944	3.569	
K1126	0.331	1.104	1.803	2.355	3.164	4.416		
K1127	0.552	1.619	2.392	3.128	4.048	5.520		

$$P = (\text{kW}) \quad TN (\text{Nm}) = \frac{P \cdot 9550}{n}$$

Performance: hardened: 2.5 x value indicated
nitrided: 1.5 x value indicated

SF = 1.4 (safety factor for tooth root stress).

SH = 1.0 (safety factor for hertzian stress) for continuous operation.

All dimensions are subject to change without notice.

Metric Bevel Gears

Ratio 1:1.5 Pressure Angle 20° Material: Steel 34 Cr 4

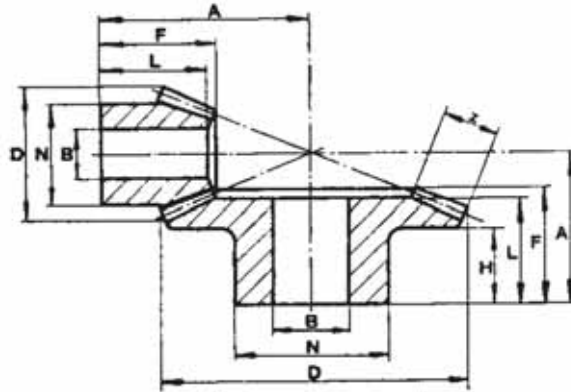

Ratio 1:1.5

Module	No. of Teeth	Dimensions in mm								Part No.
		B _{H7}	N	D	H	L	F	A	Z	
1.5	16	8	18	26.5	10.0	17.8	18.8	30	7.6	K1150
	24	10	22	37.7	11.5	18.5	20.0	27	7.6	
2.0	16	11	22	35.3	10.0	19.1	21.1	36	10.1	K1151
	24	13	26	50.2	12.0	18.7	21.7	31	10.1	
2.5	16	14	28	44.1	10.5	21.9	24.4	43	12.6	K1152
	24	16	32	62.8	14.0	22.6	26.4	38	12.6	
3.0	16	17	34	53.0	11.0	24.7	27.7	50	15.1	K1153
	24	19	38	75.3	16.5	26.5	31.0	45	15.1	
3.5	16	20	40	61.8	12.5	28.5	32.0	58	17.7	K1154
	24	23	46	87.9	20.5	32.4	37.7	54	17.7	
4.0	16	23	46	70.6	14.0	32.2	36.2	66	20.2	K1155
	24	26	52	100.4	23.0	36.3	42.3	61	20.2	
4.5	16	25	50	79.4	16.5	37.0	41.5	75	22.7	K1156
	24	29	58	113.0	25.0	40.2	47.0	68	22.7	
5.0	16	28	56	88.3	17.5	39.8	44.8	82	25.5	K1157
	24	32	64	125.5	28.0	44.3	51.8	75	25.5	

Maximum capacity kW

Part No.	rpm (n)							
	100	300	500	700	1000	1500	2000	2500
K1150	0.036	0.081	0.147	0.165	0.184	0.257	0.353	0.772
K1151	0.143	0.184	0.294	0.331	0.404	0.588	0.736	0.883
K1152	0.179	0.294	0.404	0.588	0.772	1.104	1.361	1.700
K1153	0.210	0.552	0.846	1.067	1.361	1.803	2.208	2.723
K1154	0.294	0.883	1.214	1.545	2.100	2.796	3.459	
K1155	0.368	1.067	1.692	2.208	2.980	4.084	5.115	
K1156	0.441	1.472	2.355	3.128	4.268	5.556		
K1157	0.662	2.097	3.201	4.195	5.483	7.360		

$$P = (\text{kW}) \quad TN \text{ (Nm)} = \frac{P \cdot 9550}{n}$$

Performance: hardened: 2.5 x value indicated
nitrided: 1.5 x value indicated

SF = 1.4 (safety factor for tooth root stress).

SH = 1.0 (safety factor for hertzian stress) for continuous operation.

All dimensions are subject to change without notice.

Metric Bevel Gears

Ratio 1:2 Pressure Angle 20° Material: Steel 34 Cr 4

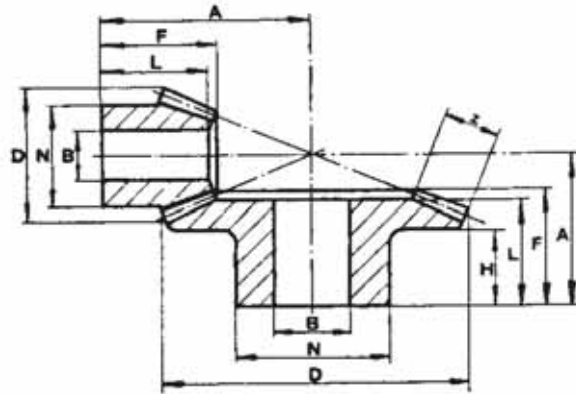

Ratio 1:2

Module	No. of Teeth	Dimensions in mm								Part No.
		B _{h7}	N	D	H	L	F	A	Z	
1.5	15	8	18	25.5	10.4	18.8	19.8	34	8.8	K1200
	30	11	24	46.3	12.0	17.6	19.6	26	8.8	
2.0	15	11	22	33.6	10.0	21.6	23.1	42	11.7	K1201
	30	14	28	61.8	12.4	19.6	22.4	31	11.7	
2.5	15	14	28	41.9	11.2	25.5	27.3	51	14.7	K1202
	30	18	36	77.2	15.8	24.8	28.3	39	14.7	
3.0	15	17	34	50.4	13.2	30.5	32.6	61	17.6	K1203
	30	22	44	92.7	20.1	30.9	35.1	48	17.6	
3.5	15	20	40	58.8	14.4	34.4	36.9	70	20.5	K1204
	30	25	50	108.1	22.5	35.1	40.0	55	20.5	
4.0	15	23	46	67.1	15.5	38.4	41.2	79	23.5	K1205
	30	30	60	123.6	27.8	42.2	47.8	65	23.5	
4.5	15	26	52	75.5	16.7	42.2	45.4	88	26.4	K1206
	30	34	68	139.0	31.1	47.4	53.7	73	26.4	
5.0	15	29	58	83.9	17.8	46.2	49.7	97	29.3	K1207
	30	37	74	154.5	33.5	51.5	58.5	80	29.3	

Maximum capacity kW

Part No.	rpm (n)							
	100	300	500	700	1000	1500	2000	2500
K1200	0.073	0.084	0.149	0.184	0.220	0.331	0.404	0.478
K1201	0.145	0.169	0.220	0.331	0.478	0.625	0.883	1.030
K1202	0.181	0.309	0.478	0.588	0.883	1.214	1.619	1.913
K1203	0.215	0.588	0.956	1.251	1.620	2.134	2.539	2.800
K1204	0.331	0.846	1.324	1.729	2.281	3.128	3.841	
K1205	0.515	1.214	1.840	2.465	3.275	4.416	5.372	
K1206	0.588	1.656	2.576	3.385	4.500	6.108		
K1207	0.662	2.208	3.460	4.490	5.961	7.875		

$$P = (\text{kW}) \quad T_N (\text{Nm}) = \frac{P \cdot 9550}{n}$$

Performance: hardened: 2.5 x value indicated
nitrided: 1.5 x value indicated

SF = 1.4 (safety factor for tooth root stress).

SH = 1.0 (safety factor for hertzian stress) for continuous operation.

All dimensions are subject to change without notice.

Metric Bevel Gears

Ratio 1:2.5 Pressure Angle 20° Material: Steel 34 Cr 4

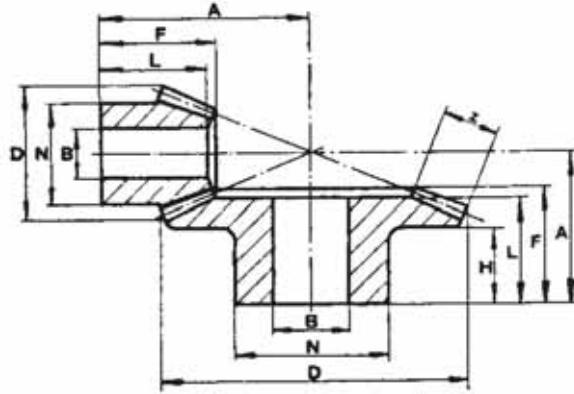

Ratio 1:2.5

Module	No. of Teeth	Dimensions in mm								Part No.
		B _{n7}	N	D	H	L	F	A	Z	
1.5	16	10	20	26.8	10.4	22.0	22.9	42	11.3	K1250
	40	15	30	61.1	16.0	21.1	23.1	30	11.3	
2.0	16	12	26	35.7	10.0	27.3	28.4	54	15.1	K1251
	40	18	36	81.5	18.0	25.2	27.9	37	15.1	
2.5	16	16	32	44.6	11.2	32.7	34.1	66	18.9	K1252
	40	22	44	101.9	21.0	30.2	33.5	45	18.9	
3.0	16	20	40	53.6	13.2	38.1	39.7	78	22.6	K1253
	40	27	54	122.2	26.0	38.2	42.2	56	22.6	
3.5	16	22	46	62.5	14.4	42.2	44.3	89	26.4	K1254
	40	32	64	142.6	33.0	46.3	50.9	67	26.4	
4.0	16	26	52	71.4	15.5	47.9	50.0	101	30.2	K1255
	40	35	70	163.0	34.0	49.3	54.6	73	30.2	
4.5	16	30	60	80.4	16.7	53.2	55.6	113	33.9	K1256
	40	40	80	183.3	37.0	54.3	60.3	81	33.9	
5.0	16	32	66	89.3	17.8	57.6	60.3	124	37.7	K1257
	40	45	89	203.7	40.0	60.3	67.0	90	37.7	

Maximum capacity kW

Part No.	rpm (n)							
	100	300	500	700	1000	1500	2000	2500
K1250	0.088	0.103	0.184	0.220	0.331	0.404	0.552	0.625
K1251	0.147	0.220	0.368	0.515	0.625	0.809	1.067	1.251
K1252	0.183	0.404	0.625	0.883	1.140	1.619	2.060	2.502
K1253	0.218	0.700	1.140	1.545	2.060	2.760	3.238	
K1254	0.404	1.104	1.803	2.281	3.017	4.048	4.970	
K1255	0.588	1.656	2.539	3.312	4.268	5.704		
K1256	0.736	2.208	3.460	4.563	6.035	7.948		
K1257	0.920	2.944	4.563	5.924	7.801			

$$P = (\text{kW}) \quad T_N (\text{Nm}) = \frac{P \cdot 9550}{n}$$

Performance: hardened: 2.5 x value indicated
nitrided: 1.5 x value indicated

SF = 1.4 (safety factor for tooth root stress).

SH = 1.0 (safety factor for hertzian stress) for continuous operation.

All dimensions are subject to change without notice.

Metric Bevel Gears

Ratio 1:3 Pressure Angle 20° Material: Steel 34 Cr 4

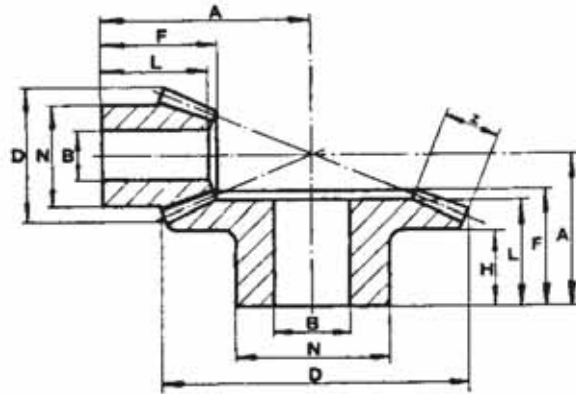

Ratio 1:3

Module	No. of Teeth	Dimensions in mm								Part No.
		B _{h7}	N	D	H	L	F	A	Z	
1.5	15	10	19	25.3	11.7	21.1	22.3	46	10.3	K1300
	45	15	30	68.4	15.0	20.8	23.0	30	10.3	
2.0	15	12	24	33.8	13.0	26.5	27.4	59	13.8	K1301
	45	17	34	91.3	20.0	26.9	29.7	39	13.8	
2.5	15	16	32	42.2	14.8	31.4	32.6	72	17.2	K1302
	45	24	48	114.1	26.0	34.8	38.3	50	17.2	
3.0	15	19	38	50.7	17.3	37.3	38.7	86	20.6	K1303
	45	28	56	136.9	30.0	40.7	45.0	59	20.6	
3.5	15	22	44	59.1	18.9	42.3	43.9	99	24.1	K1304
	45	32	65	159.7	35.0	47.8	52.7	69	24.1	
4.0	15	25	50	67.6	20.3	47.3	49.0	112	27.5	K1305
	45	36	72	182.5	39.0	52.9	58.4	77	27.5	
4.5	15	28	56	76.0	20.9	51.0	53.1	124	31.0	K1306
	45	40	80	205.3	43.0	58.7	65.0	86	31.0	

Maximum capacity kW

Part No.	rpm (n)							
	100	300	500	700	1000	1500	2000	2500
K1300	0.090	0.125	0.147	0.220	0.257	0.282	0.478	0.588
K1301	0.148	0.162	0.220	0.368	0.515	0.736	1.067	1.325
K1302	0.185	0.300	0.441	0.588	0.883	1.361	1.825	2.208
K1303	0.220	0.588	1.030	1.324	1.803	2.400	2.907	
K1304	0.368	1.030	1.620	2.100	2.800	3.680	4.416	
K1305	0.588	1.619	2.400	3.164	4.048	5.446		
K1306	0.883	2.800	4.342	5.704	7.433	9.998		

$$P = (\text{kW}) \quad T_N (\text{Nm}) = \frac{P \cdot 9550}{n}$$

Performance: hardened: 2.5 x value indicated
nitrided: 1.5 x value indicated

SF = 1.4 (safety factor for tooth root stress).

SH = 1.0 (safety factor for hertzian stress) for continuous operation.

All dimensions are subject to change without notice.

Metric Bevel Gears

Ratio 1:3.5 Pressure Angle 20° Material: Steel 34 Cr 4

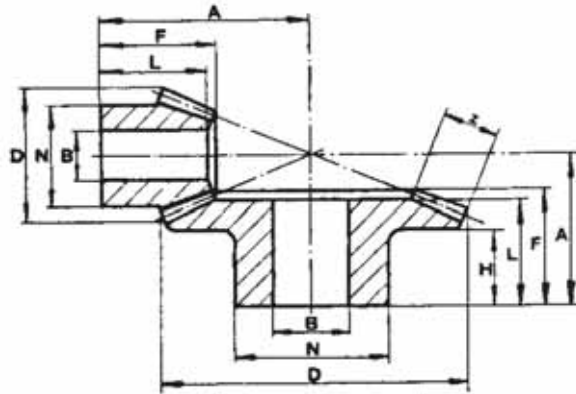

Ratio 1:3.5

Module	No. of Teeth	Dimensions in mm								Part No.
		B _{n7}	N	D	H	L	F	A	Z	
1.5	16	10	20	26.9	11.4	23.1	23.6	54	11.8	K1350
	56	16	32	84.8	18.0	23.0	25.3	33	11.8	
2.0	16	14	28	35.1	14.4	29.6	30.5	71	15.7	K1351
	56	21	42	113.1	23.0	29.6	32.7	43	15.7	
2.5	16	17	34	44.8	16.2	35.3	36.4	87	19.7	K1352
	56	26	52	141.4	29.0	36.2	40.2	53	19.7	
3.0	16	21	42	53.8	18.1	41.0	42.3	103	23.6	K1353
	56	32	64	169.6	36.0	45.0	49.6	65	23.6	
3.5	16	24	48	62.7	19.9	46.9	48.2	119	27.5	K1354
	56	36	72	197.9	39.0	49.5	55.1	73	27.5	

Maximum capacity kW

Part No.	rpm (n)							
	100	300	500	700	1000	1500	2000	2500
K1350	0.092	0.128	0.165	0.182	0.291	0.355	0.448	0.552
K1351	0.117	0.184	0.309	0.419	0.552	0.846	1.030	1.251
K1352	0.176	0.368	0.566	0.846	1.067	1.472	1.840	2.281
K1353	0.300	0.588	1.037	1.324	1.840	2.576	3.164	
K1354	1.008	1.582	2.060	2.760	3.900			

$$P = (\text{kW}) \quad TN (\text{Nm}) = \frac{P \cdot 9550}{n}$$

Performance: hardened: 2.5 x value indicated
nitrided: 1.5 x value indicated

SF = 1.4 (safety factor for tooth root stress).

SH = 1.0 (safety factor for hertzian stress) for continuous operation.

All dimensions are subject to change without notice.

Metric Bevel Gears

Ratio 1:4 Pressure Angle 20° Material: Steel 34 Cr 4

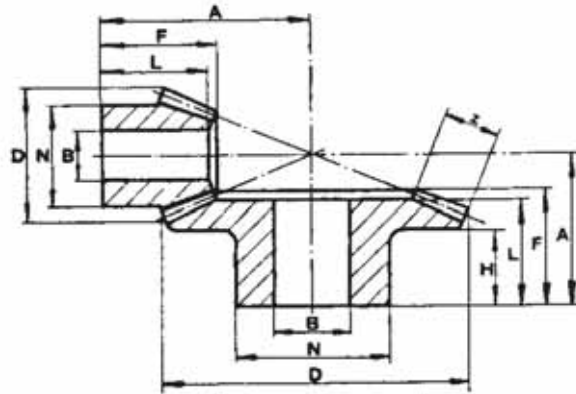

Ratio 1:4

Module	No. of Teeth	Dimensions in mm								Part No.
		B _{h7}	N	D	H	L	F	A	Z	
1.5	15	10	20	25.4	11.7	21.5	22.2	57	10.2	K1400
	60	16	32	90.7	18.0	23.0	25.4	33	10.2	
2.0	15	12	24	33.9	12.3	25.6	26.6	73	13.6	K1401
	60	21	42	121.0	23.0	29.0	32.8	43	13.6	
2.5	15	15	30	42.4	14.1	30.9	32.0	90	17.0	K1402
	60	25	50	151.2	27.5	35.0	39.3	52	17.0	
3.0	15	18	36	50.8	15.9	36.0	37.3	107	20.4	K1403
	60	30	60	181.5	32.5	41.5	46.7	62	20.4	
3.5	15	22	44	59.3	18.9	42.2	43.7	125	23.8	K1404
	60	35	70	211.7	38.5	49.4	55.1	73	23.8	

Maximum capacity kW

Part No.	rpm (n)							
	100	300	500	700	1000	1500	2000	2500
K1400	0.095	0.147	0.170	0.184	0.294	0.404	0.515	0.588
K1401	0.150	0.184	0.331	0.412	0.588	0.846	1.067	1.288
K1402	0.220	0.404	0.662	0.920	1.251	1.730	2.060	2.245
K1403	0.300	0.625	1.000	1.361	1.876	2.576	3.091	
K1404	0.404	1.067	1.700	2.248	2.980	4.011		

$$P = (\text{kW}) \quad T_N (\text{Nm}) = \frac{P \cdot 9550}{n}$$

Performance: hardened: 2.5 x value indicated
nitrided: 1.5 x value indicated

SF = 1.4 (safety factor for tooth root stress).

SH = 1.0 (safety factor for hertzian stress) for continuous operation.

All dimensions are subject to change without notice.

Metric Bevel Gears



Ratio 1:1, 1:2 Material: Plastic Hostaform C - Acetal copolymer (POM)

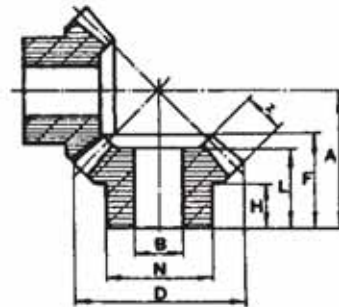
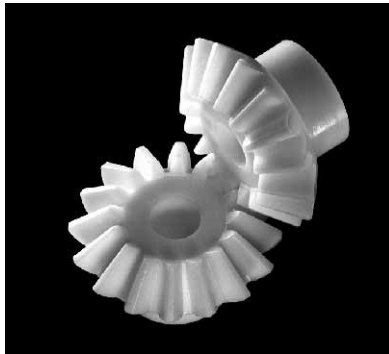

Ratio 1:1

Module	No. of Teeth	Dimensions in mm								Weight g	Part No.
		B _{h7}	N	D	H	L	F	A	Z		
0.5	16	3	7.0	8.7	6.0	8.0	8.0	10.5	2.0	0.3	KH 0516-1:1
1.0	16	5	12.0	17.6	8.0	13.6	13.6	18.4	4.7	1.9	KH 1016-1:1
1.0	30	6	15.0	31.4	7.4	12.9	15.3	24.8	7.4	5.9	KH 1030-1:1
1.5	16	8	18.5	26.4	10.0	16.2	18.4	25.8	7.0	5.9	KH 1516-1:1
2.0	16	10	21.9	34.9	9.6	18.3	21.2	30.4	10.0	10.4	KH 2016-1:1
2.5	16	12	25.2	43.5	11.5	22.9	25.5	37.0	12.3	20.0	KH 2516-1:1
3.0	16	14	28.8	52.3	13.2	25.8	29.2	43.0	13.8	32.0	KH 3016-1:1
3.5	16	18	33.3	61.4	14.4	28.1	33.1	49.5	15.8	50.0	KH 3516-1:1

1g = 0.0352736oz.

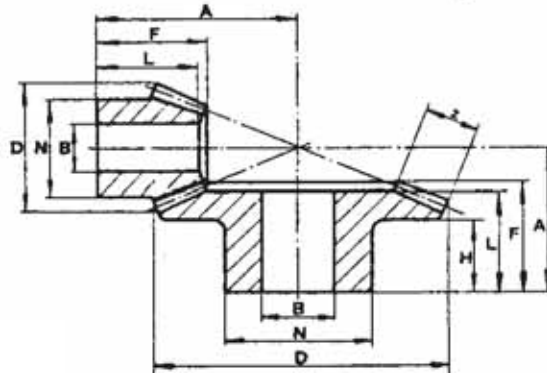
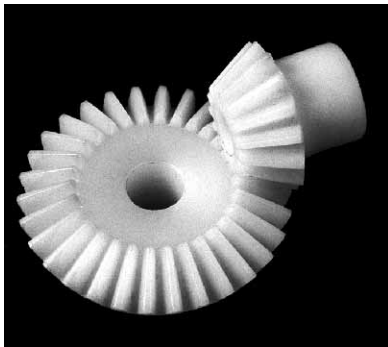

Ratio 1:2

Module	No. of Teeth	Dimensions in mm								Weight g	Part No.
		B _{h7}	N	D	H	L	F	A	Z		
1.0	15	5	12.2	16.8	10.6	17.0	17.0	26.4	6.6	2.4	KH 1015-1:2
	30	8	18.0	31.1	9.1	14.8	16.2	20.9	6.6	6.3	KH 1030-1:2
1.5	15	8	17.0	25.4	11.5	22.8	22.8	35.8	10.5	7.5	KH 1515-1:2
	30	10	23.4	46.4	9.6	17.5	19.5	26.2	10.5	17.0	KH 1530-1:2
2.0	15	10	22.5	33.6	11.8	26.0	27.0	44.2	14.6	13.3	KH 2015-1:2
	30	12	30.2	62.2	11.8	22.6	24.2	32.6	14.6	41.0	KH 2030-1:2
2.5	15	12	26.5	42	13.0	29.6	31.2	53.3	17.3	23.6	KH 2515-1:2
	30	16	36.1	77.3	15.0	27.5	29.5	40.5	17.3	69.0	KH 2530-1:2
3.0	15	14	31.2	50.3	14.8	35	36.3	63.3	20.5	38.0	KH 3015-1:2
	30	18	45.0	93	19.0	34.2	37.0	49.5	20.5	129.0	KH 3030-1:2

1g = 0.0352736oz.

All dimensions are subject to change without notice.

Metric Bevel Gears

Ratio 1:3, 1:4, 1:5 Material: Plastic Hostaform C
Acetal copolymer (POM)

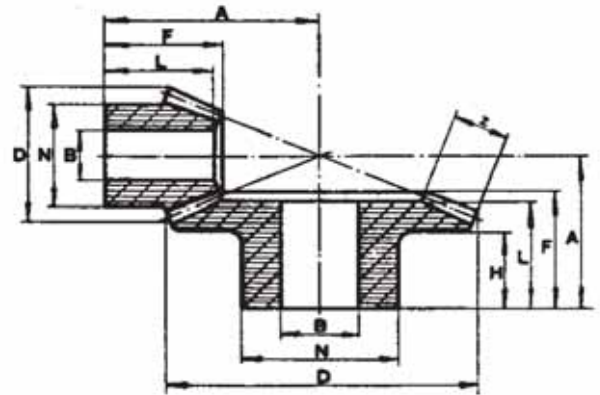
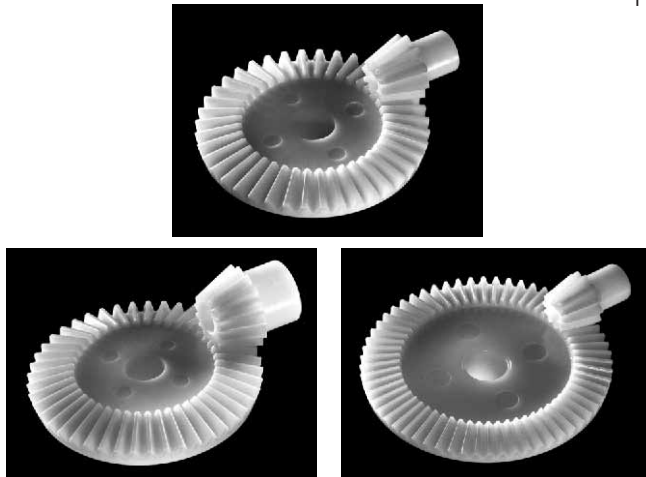

Ratio 1:3

Module	No. of Teeth	Dimensions in mm								Weight g	Part No.
		B _{h7}	N	D	H	L	F	A	Z		
1.0	15	5	12.3	16.6	11.0	20.4	20.4	34.3	9.2	2.7	KH 1015-1:3
	45	10	23.4	46.1	9.6	16.5	18.2	22.7	9.2	16.0	KH 1045-1:3
1.5	15	8	17.2	25.1	12.5	26.8	26.8	47.9	14.0	8.5	KH 1515-1:3
	45	12	30.4	68.8	11.5	21.5	23.0	29.4	14.0	49.0	KH 1545-1:3
2.0	10	6	16.6	24.0	12.0	25.0	25.0	43.7	12.5	6.1	KH 2010-1:3
	30	12	30.3	61.7	11.5	20.2	22.5	28.0	12.5	38.0	KH 2030-1:3
2.5	10	8	18.8	29.7	13.0	28.8	28.8	52.4	15.7	10.2	KH 2510-1:3
	30	18	36.1	77.2	15.5	25.2	29.0	35.7	15.7	68.0	KH 2530-1:3

1g = 0.0352736oz.

Ratio 1:4

Module	No. of Teeth	Dimensions in mm								Weight g	Part No.
		B _{h7}	N	D	H	L	F	A	Z		
1.0	10	4	7.8	12.0	9.3	17.7	17.7	30.1	8.2	0.9	KH 1010-1:4
	40	10	23.4	40.8	10.8	15.7	17.0	20.1	8.2	12.6	KH 1040-1:4
1.5	10	5	11.3	18.0	10.9	23.5	23.5	41.7	12.3	3.0	KH 1510-1:4
	40	12	30.4	61.2	12.8	20.0	21.7	26.2	12.3	32.0	KH 1540-1:4
2.0	10	6	14.3	23.8	12.8	28.9	28.9	54.0	16.3	6.4	KH 2010-1:4
	40	18	36.0	81.5	16.6	24.7	27.0	32.5	16.3	65.0	KH 2040-1:4

1g = 0.0352736oz.

Ratio 1:5

Module	No. of Teeth	Dimensions in mm								Weight g	Part No.
		B _{h7}	N	D	H	L	F	A	Z		
1.0	12	4	9.5	13.7	10	20.3	20.3	40.5	9.5	2.0	KH 1012-1:5
	60	10	20.5	60.4	11	15.5	17.4	21.0	9.5	17.0	KH 1060-1:5

1g = 0.0352736oz.

All dimensions are subject to change without notice.



T.E.A. Machine Components Inc.

Your partner in quality engineering components since 2003

Thank you for downloading product information from TEA's wide range of engineering components.

Now, please contact us for any further information, prices and delivery.

Our contact details are:

T.E.A. Machine Components Inc.
2281-F Dabney Road
Virginia 23230
U.S.A.

Ph: +1-804-342-0004

Fax: +1-804-342-0006

Web: www.teausa.net

Email: sales@teausa.net

You are assured of prompt and efficient service at all times.