

MACHINE FOOTINGS

Material: Foot: Stainless steel AISI 304
 Thread: Stainless steel AISI 303
 Damper: Perbunan, 70° Shore A
 Includes: 2 hex. Nuts DIN 934
 All sizes are generally in stock

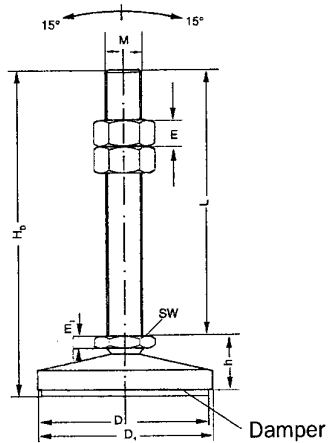

All dimensions in mm

Part No.	Thread	D	D ₁	h	HD	L	m	m ₁	SW	Load lb.f
MF 8.40 SS	M8	37	40	13	73	60	6.5	2.6	13	449
MF10.60 SS	M10	57	60	18	88	70	8	3.2	17	674
MF12.60 SS	M12	57	60	18	98	80	10	3.7	19	899
MF14.80 SS	M14	75	80	26	126	100	11	4.4	22	2248
MF16.80 SS	M16	75	80	26	146	120	13	5.0	24	3372
MF20.100SS	M20	95	100	30	180	150	16	6.5	30	4496
MF24.100SS	M24	95	100	30	210	180	18	7.5	36	5620

All dimensions subject to change without notice